

# VXC - MC

VORTEX and DOUBLE-CHANNEL submersible pumps



**MADE IN ITALY**

 **PEDROLLO**<sup>®</sup>  
*the spring of life*

# VXC

## VORTEX submersible pumps



- ※ An innovative project by Pedrollo's Research and Development department, has resulted in the new VXC, a complete range of extremely robust and reliable electric pumps.
- ※ Thanks to the enhanced oversizing of the oil-bath electric motor, shaft and bearings, the new VXC electric pumps guarantee an unprecedented service life, with high hydraulic performance, low operating costs and easy maintenance. The oil-bath motor also allows continuous operation of the electric pump, even if completely uncovered.
- ※ They are recommended in all installations for pumping waste water with suspended solid bodies up to 65 mm diameter.
- ※ The VXC series is equipped with an extremely reliable and robust VORTEX impeller with low risk of clogging.



### PERFORMANCE RANGE

- Flow rate up to **1250 l/min** (75 m<sup>3</sup>/h)
- Head up to **20 m**

### APPLICATION LIMITS

- **10 m** maximum immersion depth (with a sufficiently long power cable)
- Maximum liquid temperature **+40 °C**
- Passage of solids:
  - up to **Ø 50 mm** for VXC /50-F
  - up to **Ø 65 mm** for VXC /65-F

### CONSTRUCTION AND SAFETY STANDARDS

- **10 m** long power cable
- External float switch and control box for single-phase versions

### INSTALLATION AND USE

The VXC series of pumps, manufactured from heavy gauge robust cast iron, resistant to abrasion and long lasting, are fitted with a VORTEX impeller and therefore suitable for drainage of **refluent water, water mixed with mud, liquids containing air or gas, and putrid muds**. They are recommended for fixed installations, when placed in suitable wells, in sewers, tunnels, wells, underground car parks, etc.

### PATENTS - TRADE MARKS - MODELS

- Patent n° IT0001428923

### OPTIONS AVAILABLE ON REQUEST

- **QES** control box for three-phase pumps
- Single-phase pumps without float switch
- Other voltages or 60 Hz frequency

### GUARANTEE

► For the following versions, to validate the guarantee, the built-in thermal overload protector must be connected to the control box:

- three-phase
  - VXC 15-20-30-40/50
  - VXC 15-20-30-40/65

## CHARACTERISTIC CURVES AND PERFORMANCE DATA

50 Hz n= 2900 min<sup>-1</sup>

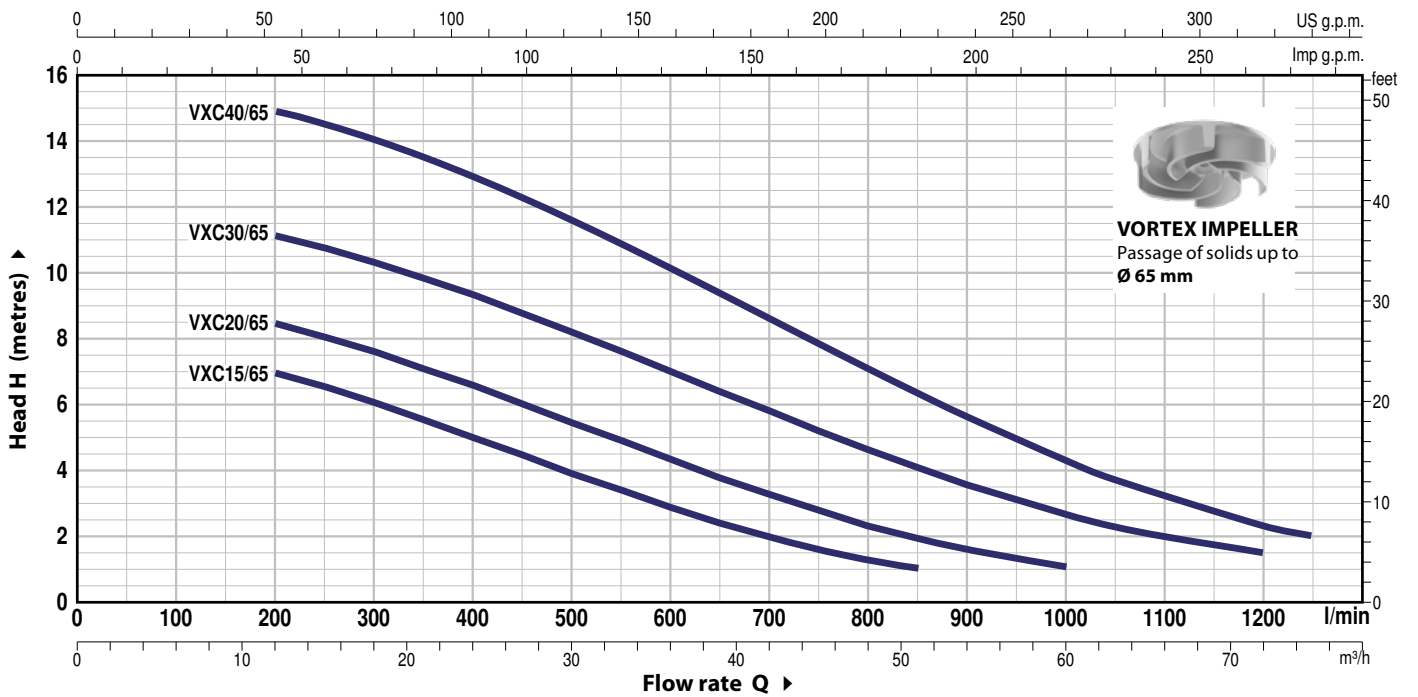
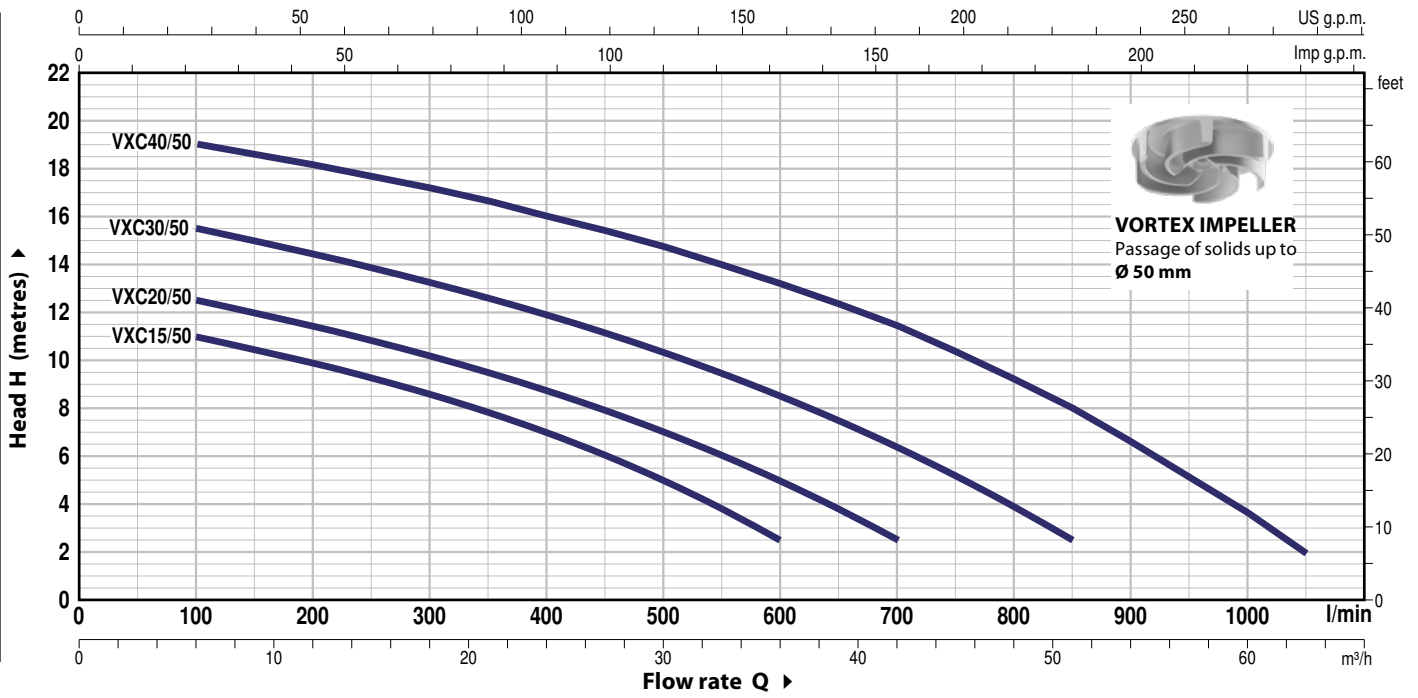

MODEL		POWER (P <sub>2</sub> )		Q	m <sup>3</sup> /h													
Single-phase	Three-phase	kW	HP		0	6	12	18	24	30	36	42	51	60	63	72	75	
				l/min	0	100	200	300	400	500	600	700	850	1000	1050	1200	1250	
VXCm 15/50	VXC 15/50	1.1	1.5	H metres	12.0	11.0	9.9	8.6	7.0	5.0	2.5							
VXCm 20/50	VXC 20/50	1.5	2		13.5	12.5	11.4	10.2	8.7	7.0	5.0	2.5						
VXCm 30/50	VXC 30/50	2.2	3		16.5	15.5	14.4	13.2	11.9	10.3	8.5	6.4	2.5					
-	VXC 40/50	3	4		20.0	19.0	18.1	17.1	16.0	14.7	13.2	11.4	8.0	3.6	2.0			
VXCm 15/65	VXC 15/65	1.1	1.5	8.0	-	7.0	6.0	5.0	3.9	2.8	2.0	1.0						
VXCm 20/65	VXC 20/65	1.5	2	9.5	-	8.5	7.6	6.6	5.4	4.3	3.3	2.0	1.0					
VXCm 30/65	VXC 30/65	2.2	3	12.0	-	11.1	10.3	9.3	8.2	7.0	5.8	4.1	2.6	2.3	1.5			
-	VXC 40/65	3	4	15.5	-	15.0	14.0	13.0	11.6	10.1	8.6	6.3	4.3	3.7	2.3	2.0		

Q = Flow rate H = Total manometric head

Tolerance of characteristic curves in compliance with EN ISO 9906 Grade 3B.

## POS. COMPONENT CONSTRUCTION CHARACTERISTICS

1	<b>PUMP BODY</b>	Cast iron with an Epoxy Electro Coating treatment, with threaded ports in compliance with ISO 228/1
2	<b>IMPELLER</b>	Precision cast stainless steel AISI 304 VORTEX type
3	<b>MOTOR CASING</b>	Cast iron with an Epoxy Electro Coating treatment
4	<b>MOTOR CASING PLATE</b>	Cast iron with an Epoxy Electro Coating treatment
5	<b>MOTOR SHAFT</b>	Stainless steel AISI 431

### 6 TWO MECHANICAL SEALS SEPARATED BY AN OIL CHAMBER

Seal Model	Shaft Diameter	Position	Materials		
			Stationary ring	Rotational ring	Elastomer
STA-22	Ø 22 mm	Motor side	Ceramic	Graphite	NBR
STA-20	Ø 20 mm	Pump side	Silicon carbide	Silicon carbide	NBR

### 7 BEARINGS 6305 CM D 6 / 6204 ZZ - C3

### 8 ELECTRIC MOTOR

**VXCm 15-20-30:** single-phase 230 V - 50 Hz  
with thermal overload protector incorporated into the winding

**VXC:** three-phase 400 V - 50 Hz.  
with thermal overload protector incorporated into the winding to be connected to the control box (supplied on demand)

- Insulation: class F
- Protection: IP X8

### 9 POWER CABLE

10 metres long "H07 RN-F" cable

### 10 CONTROL BOX for VXCm 15-20-30

(only for single-phase versions)

Complete with capacitor and manual reset motor protector

### 11 FLOAT SWITCH

(only for single-phase versions)

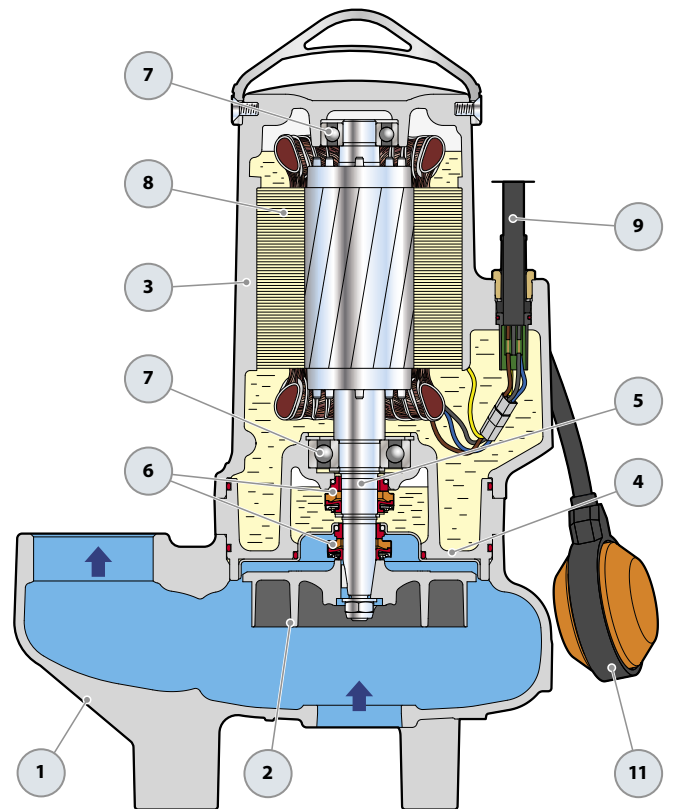

### OPTIONAL – Supporting Base



### Standard features

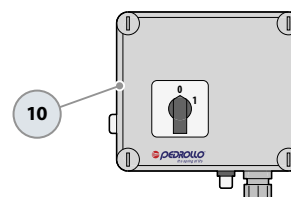

Control box  
(only for single-phase versions)

## DIMENSIONS AND WEIGHT

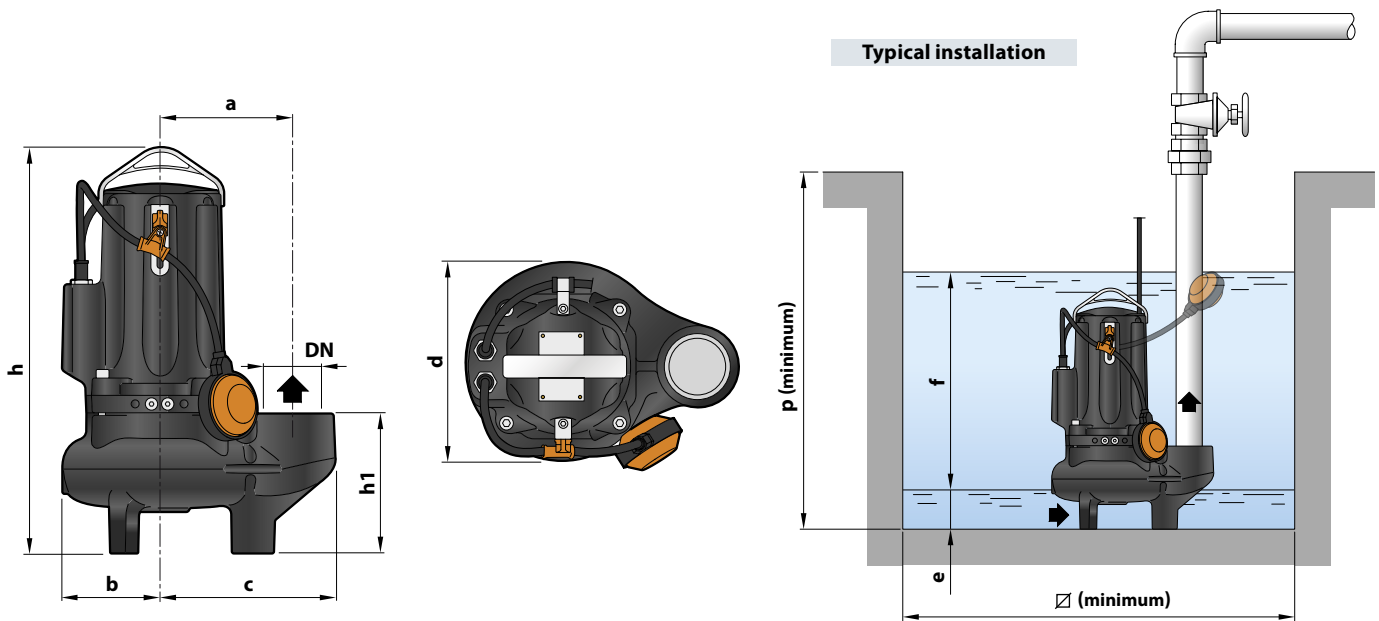

MODEL		PORT DN	Passage of solids	DIMENSIONS mm										kg	
Single-phase	Three-phase			a	b	c	h	h1	d	e	f	p	∅	1~	3~
VXCm 15/50	VXC 15/50	2½"	Ø 50	162	119	212	487	167	242	75	variable	800	800	42.0	40.5
VXCm 20/50	VXC 20/50						513   487							43.0	42.0
VXCm 30/50	VXC 30/50						513							48.0	43.0
-	VXC 40/50						-							-	48.0
VXCm 15/65	VXC 15/65	3"	Ø 65	180	120	240	521	201	246	85	variable	800	800	44.0	42.5
VXCm 20/65	VXC 20/65						547   521							45.0	44.0
VXCm 30/65	VXC 30/65						547							50.0	45.0
-	VXC 40/65						-							-	50.0

## ABSORPTION AND CAPACITORS

MODEL	VOLTAGE	
Single-phase	230 V	240 V
VXCm 15/50	8.5 A	8.1 A
VXCm 20/50	9.0 A	8.6 A
VXCm 30/50	12.0 A	11.5 A
VXCm 15/65	8.5 A	8.1 A
VXCm 20/65	9.0 A	8.6 A
VXCm 30/65	12.0 A	11.5 A

MODEL	VOLTAGE		
Three-phase	230-240 V	400-415 V	690-720 V
VXC 15/50	5.9 A	3.4 A	1.7 A
VXC 20/50	6.4 A	3.7 A	2.0 A
VXC 30/50	8.7 A	5.0 A	3.3 A
VXC 40/50	10.7 A	6.2 A	4.5 A
VXC 15/65	5.9 A	3.4 A	1.7 A
VXC 20/65	6.4 A	3.7 A	2.0 A
VXC 30/65	8.7 A	5.0 A	3.3 A
VXC 40/65	10.7 A	6.2 A	4.5 A

MODEL	CAPACITANCE CAPACITORS
Single-phase	(230 V o 240 V)
VXCm 15/50 VXCm 15/65	50 µF 450 VL
VXCm 20/50 VXCm 20/65	50 µF 450 VL
VXCm 30/50 VXCm 30/65	60 µF 450 VL

# MC

## Submersible pumps **DOUBLE-CHANNEL**

 Sewage water

 Domestic use

 Civil use

 Industrial use

- ※ An innovative project by Pedrollo's Research and Development department, has resulted in the new **MC**, a complete range of extremely robust and reliable electric pumps.
- ※ Thanks to the enhanced oversizing of the oil-bath electric motor, shaft and bearings, the new **MC** electric pumps guarantee an unprecedented service life, with high hydraulic performance, low operating costs and easy maintenance. The oil-bath motor also allows continuous operation of the electric pump, even if partially uncovered.
- ※ They are recommended in all installations for pumping waste water with suspended solid bodies up to 65 mm diameter.
- ※ The **MC** series is equipped with a double-channel impeller, ideal for the discharge of large volumes of waste water.



### PERFORMANCE RANGE

- Flow rate up to **1600 l/min** (96 m<sup>3</sup>/h)
- Head up to **25 m**

### APPLICATION LIMITS

- **10 m** maximum immersion depth (with a sufficiently long power cable)
- Maximum liquid temperature **+40 °C**
- Passage of solids:
  - up to **Ø 50 mm** for MC /50
  - up to **Ø 65 mm** for MC /65
- Minimum immersion depth for continuous service:
  - **320 mm** for MC /50
  - **360 mm** for MC /65

### CONSTRUCTION AND SAFETY STANDARDS

- **10 m** long power cable
- External float switch and control box for single-phase versions

### INSTALLATION AND USE

**MC** series pumps, made from heavy gauge robust cast iron, resistant to abrasion and long-lasting, are fitted with a **DOUBLE-CHANNEL** impeller and are capable of pumping liquids containing short fibred suspended solids. They are ideal for pumping **sewage, waste water, water mixed with mud, groundwater and surface water** in locations such as blocks of flats, public buildings, factories, multi-storey and underground car parks, washing areas, etc.

### PATENTS - TRADE MARKS - MODELS

- Patent n° IT0001428923

### OPTIONS AVAILABLE ON REQUEST

- **QES** control box for three-phase pumps
- Single-phase pumps without float switch
- Other voltages or 60 Hz frequency

### GUARANTEE

- ▣ **For the following versions, to validate the guarantee, the built-in thermal overload protector must be connected to the control box:**
  - three-phase
    - **MC 15-20-30-40/50**
    - **MC 30-40/65**

## CHARACTERISTIC CURVES AND PERFORMANCE DATA

50 Hz n= 2900 min<sup>-1</sup>

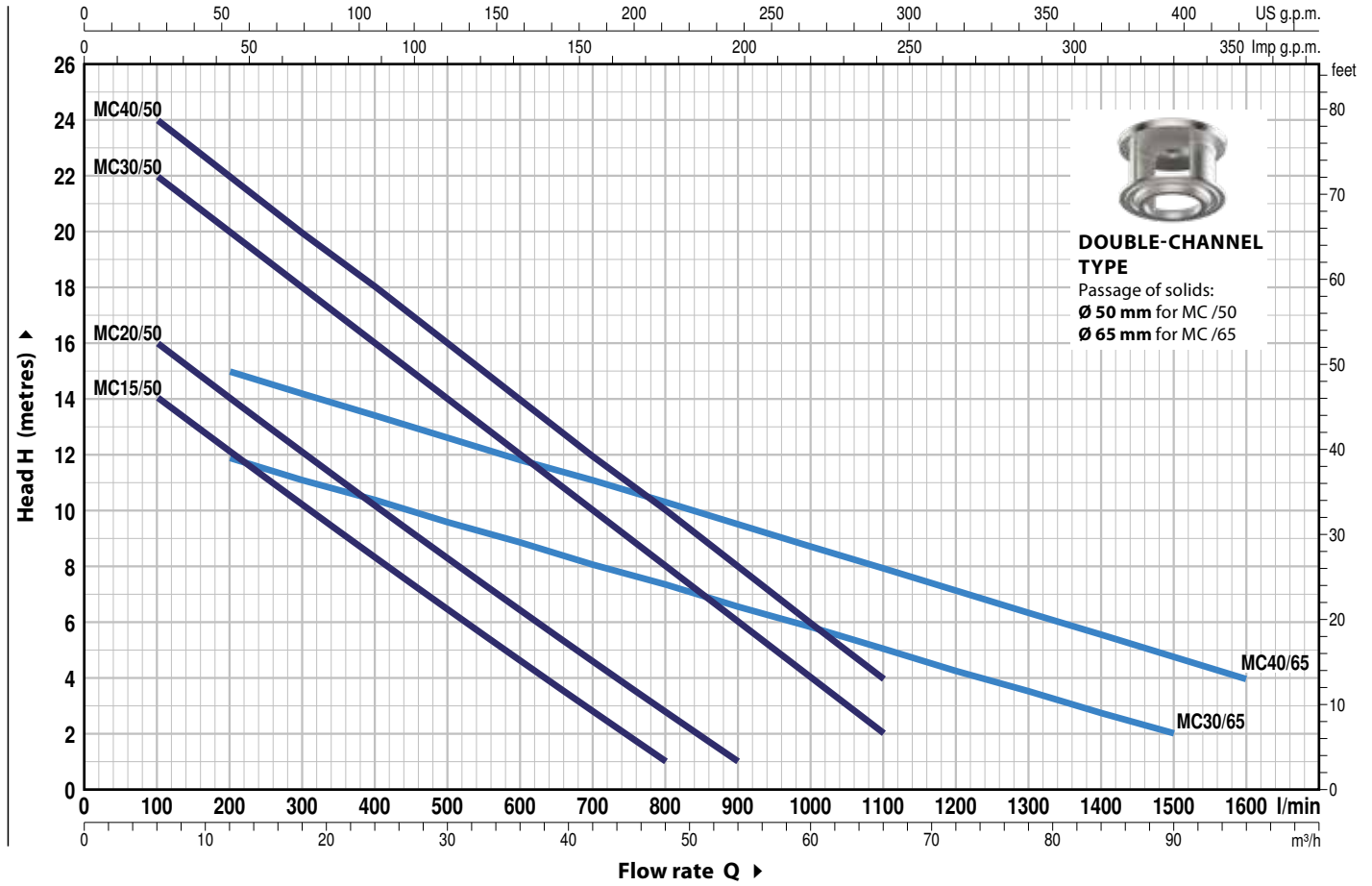

MODEL		POWER (P <sub>2</sub> )		Q	m <sup>3</sup> /h															
Single-phase	Three-phase	kW	HP		0	6	12	18	24	30	36	42	48	54	60	66	72	90	96	
				l/min	0	100	200	300	400	500	600	700	800	900	1000	1100	1200	1500	1600	
MCm 15/50	MC 15/50	1.1	1.5	H metres	16	14	12.5	10.5	8.5	6.5	4.5	3	1							
MCm 20/50	MC 20/50	1.5	2		18	16	14	12.5	10.5	8.5	6.5	5	3	1						
MCm 30/50	MC 30/50	2.2	3		24	22	20	18	16	14	12	10	8	6	4	2				
-	MC 40/50	3	4		25	24	22	20	18	16	14	12	10	8	6	4				
MCm 30/65	MC 30/65	2.2	3		13	-	12	11	10.5	9.7	9	8	7.5	6.5	6	5	4.5	2		
-	MC 40/65	3	4		17	-	15	14	13.5	12.5	12	11	10.5	9.5	8.5	8	7	4.8	4	

Q = Flow rate H = Total manometric head

Tolerance of characteristic curves in compliance with EN ISO 9906 Grade 3B.

**POS. COMPONENT CONSTRUCTION CHARACTERISTICS**

<b>1 PUMP BODY</b>	Cast iron with an Epoxy Electro Coating treatment, with threaded ports in compliance with ISO 228/1
<b>2 IMPELLER</b>	Precision cast stainless steel AISI 304 DOUBLE-CHANNEL type
<b>3 MOTOR CASING</b>	Cast iron with an Epoxy Electro Coating treatment
<b>4 MOTOR CASING PLATE</b>	Cast iron with an Epoxy Electro Coating treatment
<b>5 MOTOR SHAFT</b>	Stainless steel AISI 431

**6 TWO MECHANICAL SEALS SEPARATED BY AN OIL CHAMBER**

Seal Model	Shaft Diameter	Position	Materials		
			Stationary ring	Rotational ring	Elastomer
STA-22	Ø 22 mm	Motor side	Ceramic	Graphite	NBR
STA-20	Ø 20 mm	Pump side	Silicon carbide	Silicon carbide	NBR

**7 BEARINGS 6305 CM D 6 / 6204 ZZ - C3**

**8 ELECTRIC MOTOR**

**MCm 15-20-30:** single-phase 230 V - 50 Hz with thermal overload protector incorporated into the winding

**MC:** three-phase 400 V - 50 Hz. with thermal overload protector incorporated into the winding to be connected to the control box (supplied on demand)

- Insulation: class F
- Protection: IP X8

**9 POWER CABLE**

**10 metres** long "H07 RN-F" cable

**10 CONTROL BOX for MCm 15-20-30**

(only for single-phase versions)

Complete with capacitor and manual reset motor protector

**11 FLOAT SWITCH**

(only for single-phase versions)

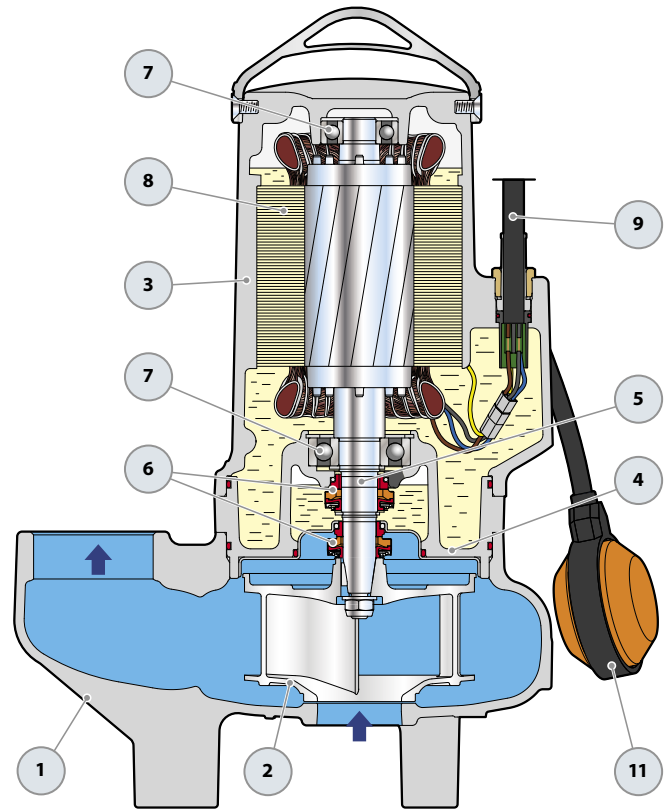

**OPTIONAL – Supporting Base**



**Standard Equipment**

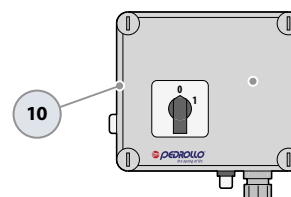

**Control Box**  
(only for single-phase versions)

## DIMENSIONS AND WEIGHT

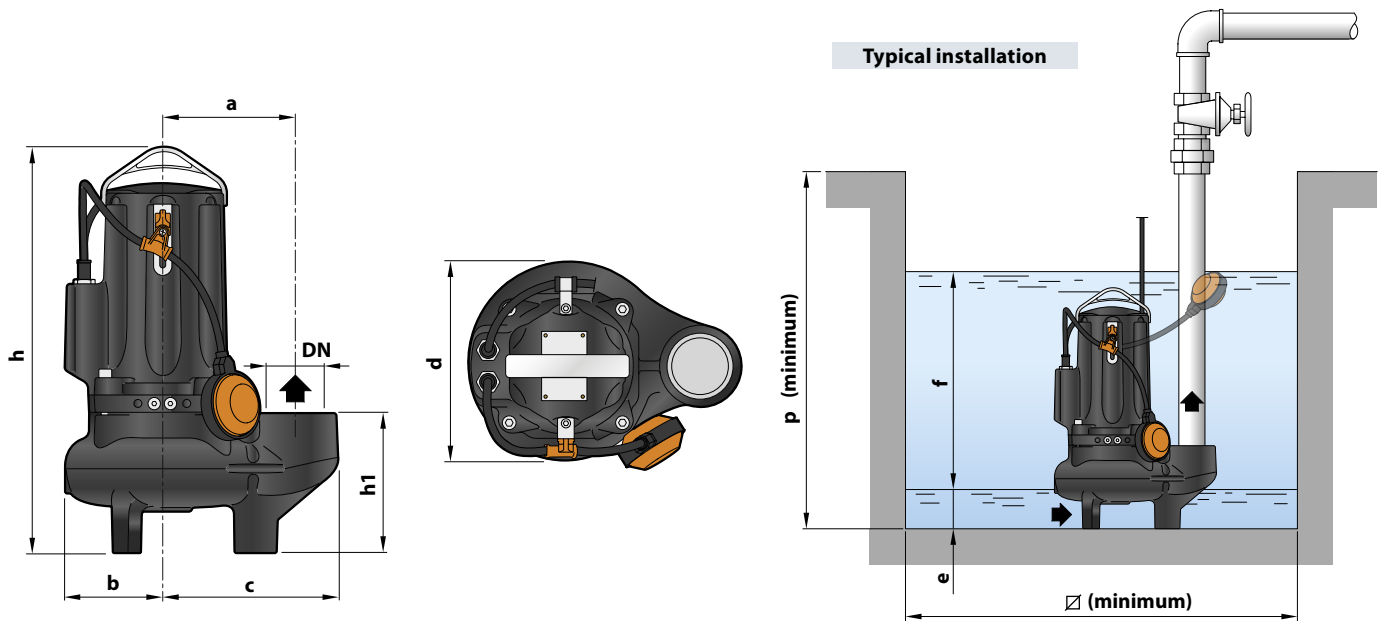

MODEL		PORT DN	Passage of solids	DIMENSIONS mm										kg	
Single-phase	Three-phase			a	b	c	h	h1	d	e	f	p	Ø	1~	3~
MCm 15/50	MC 15/50	2½"	Ø 50	162	119	212	487	167	242	75	variable	800	800	42.0	40.5
MCm 20/50	MC 20/50						513   487							43.0	42.0
MCm 30/50	MC 30/50						513							48.0	43.0
-	MC 40/50						513							-	48.0
MCm 30/65	MC 30/65	3"	Ø 65	180	120	240	547   521	201	246	85	variable	800	800	50.0	45.0
-	MC 40/65						547							-	50.0

## ABSORPTION AND CAPACITORS

MODEL	VOLTAGE	
	230 V	240 V
Single-phase	230 V	240 V
MCm 15/50	10.5 A	10.1 A
MCm 20/50	14.0 A	13.4 A
MCm 30/50	18.0 A	17.3 A
MCm 30/65	14.0 A	13.4 A

MODEL	VOLTAGE		
	230-240 V	400-415 V	690-720 V
Three-phase	230-240 V	400-415 V	690-720 V
MC 15/50	7.8 A	4.5 A	2.8 A
MC 20/50	8.7 A	5.0 A	3.3 A
MC 30/50	10.4 A	6.0 A	4.3 A
MC 40/50	11.2 A	6.5 A	4.8 A
MC 30/65	9.5 A	5.5 A	3.8 A
MC 40/65	13.0 A	7.5 A	5.8 A

MODEL	CAPACITANCE CAPACITORS
	(230 V o 240 V)
Single-phase	(230 V o 240 V)
MCm 15/50	50 µF 450 VL
MCm 20/50	50 µF 450 VL
MCm 30/50 MCm 30/65	60 µF 450 VL

# VXC-F

## VORTEX Submersible Pumps with flanged ports



- ※ An innovative project by Pedrollo's Research and Development department, has resulted in the new VXC-F, a complete range of extremely robust and reliable electric pumps.
- ※ Thanks to the enhanced oversizing of the oil-bath electric motor, shaft and bearings, the new VXC-F electric pumps guarantee an unprecedented service life, with high hydraulic performance, low operating costs and easy maintenance. The oil-bath motor also allows continuous operation of the electric pump, even if completely uncovered.
- ※ They are recommended in all installations for pumping waste water with suspended solid bodies up to 65 mm diameter.
- ※ The VXC-F series is equipped with an extremely reliable and robust VORTEX impeller with low risk of clogging.



### PERFORMANCE RANGE

- Flow rate up to **1250 l/min** (75 m<sup>3</sup>/h)
- Head up to **20 m**

### APPLICATION LIMITS

- **10 m** maximum immersion depth (with a sufficiently long power cable)
- Maximum liquid temperature **+40 °C**
- Passage of solids:
  - up to **Ø 50 mm** for VXC /50-F
  - up to **Ø 65 mm** for VXC /65-F

### CONSTRUCTION AND SAFETY STANDARDS

- **10 m** long power cable
- External float switch and control box for single-phase versions

### INSTALLATION AND USE

The **VXC-F** series of pumps, manufactured from heavy gauge robust cast iron, resistant to abrasion and long lasting, are fitted with a VORTEX impeller and therefore suitable for drainage of **refluent water, water mixed with mud, liquids containing air or gas, and putrid muds**. They are recommended for fixed installations, when placed in suitable wells, in sewers, tunnels, wells, underground car parks, etc.

### PATENTS - TRADE MARKS - MODELS

- Patent n° IT0001428923

### OPTIONS AVAILABLE ON REQUEST

- Connection support KIT
- **QES** control box for three-phase pumps
- Single-phase pumps without float switch
- Other voltages or 60 Hz frequency

### GUARANTEE

- ▶ **For the following versions, to validate the guarantee, the built-in thermal overload protector must be connected to the control box:**
  - three-phase
    - **VXC 15-20-30-40/50-F**
    - **VXC 15-20-30-40/65-F**

## CHARACTERISTIC CURVES AND PERFORMANCE DATA

50 Hz n= 2900 min<sup>-1</sup>

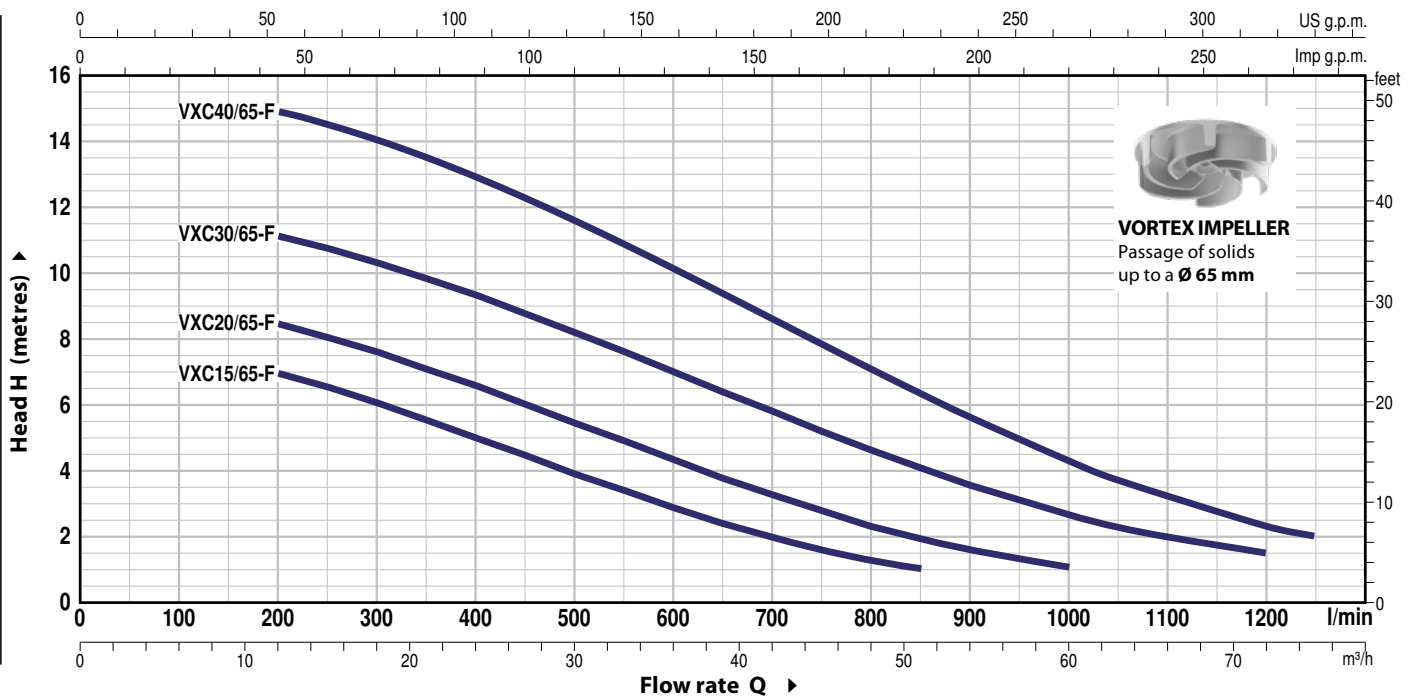
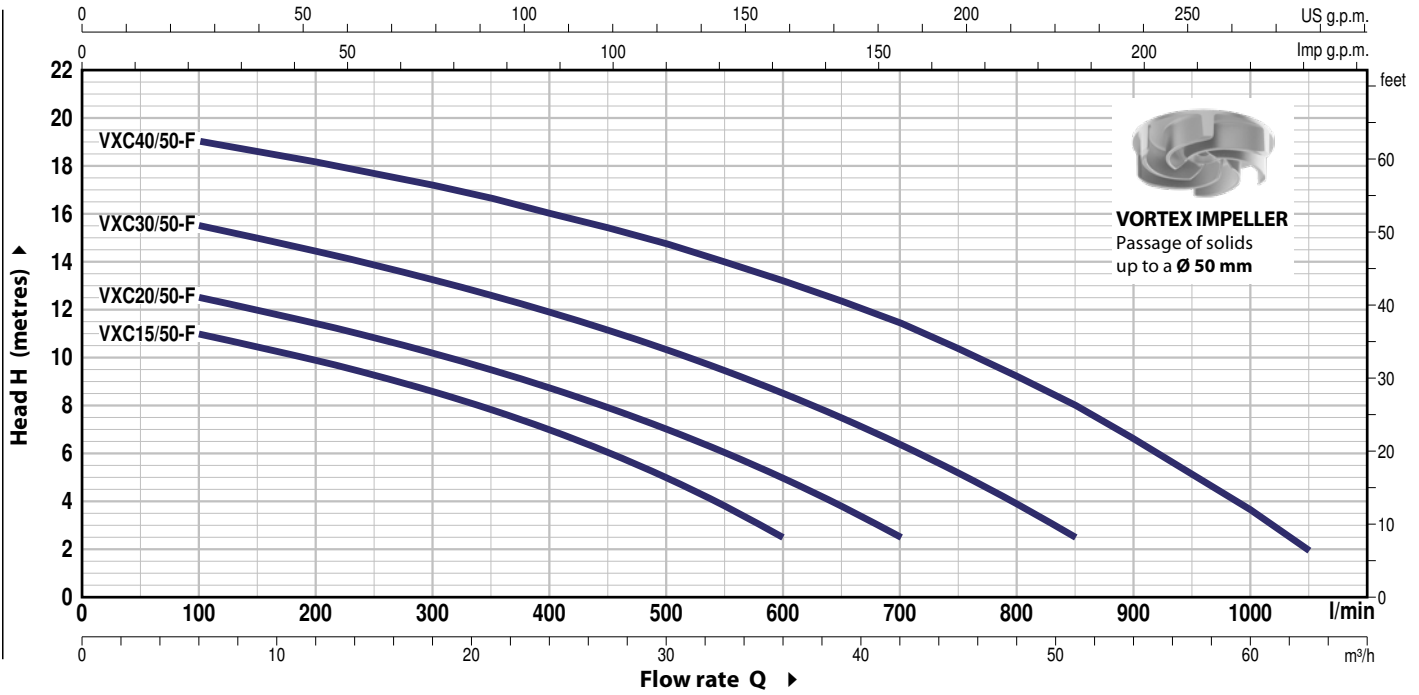

MODEL		POWER (P2)		Q	Flow rate														
Single-phase	Three-phase	kW	HP		m³/h	0	6	12	18	24	30	36	42	51	60	63	72	75	
				l/min	0	100	200	300	400	500	600	700	850	1000	1050	1200	1250		
VXCm 15/50-F	VXC 15/50-F	1.1	1.5	H metri	12.0	11.0	9.9	8.6	7.0	5.0	2.5								
VXCm 20/50-F	VXC 20/50-F	1.5	2		13.5	12.5	11.4	10.2	8.7	7.0	5.0	2.5							
VXCm 30/50-F	VXC 30/50-F	2.2	3		16.5	15.5	14.4	13.2	11.9	10.3	8.5	6.4	2.5						
-	VXC 40/50-F	3	4		20.0	19.0	18.1	17.1	16.0	14.7	13.2	11.4	8.0	3.6	2.0				
VXCm 15/65-F	VXC 15/65-F	1.1	1.5		8.0	-	7.0	6.0	5.0	3.9	2.8	2.0	1.0						
VXCm 20/65-F	VXC 20/65-F	1.5	2		9.5	-	8.5	7.6	6.6	5.4	4.3	3.3	2.0	1.0					
VXCm 30/65-F	VXC 30/65-F	2.2	3		12.0	-	11.1	10.3	9.3	8.2	7.0	5.8	4.1	2.6	2.3	1.5			
-	VXC 40/65-F	3	4		15.5	-	15.0	14.0	13.0	11.6	10.1	8.6	6.3	4.3	3.7	2.3	2.0		

Q = Flow rate H = Total manometric head

Tolerance of characteristic curves in compliance with EN ISO 9906 Grade 3B.

**POS. COMPONENT CONSTRUCTION CHARACTERISTICS**

<b>1 PUMP BODY</b>	Cast iron with an Epoxy Electro Coating treatment, with flanged and threaded ports in compliance with ISO 228/1
<b>2 IMPELLER</b>	VORTEX type in cast iron with an Epoxy Electro Coating treatment
<b>3 MOTOR CASING</b>	Cast iron with an Epoxy Electro Coating treatment
<b>4 MOTOR CASING PLATE</b>	Cast iron with an Epoxy Electro Coating treatment
<b>5 MOTOR SHAFT</b>	Stainless steel AISI 431

**6 TWO MECHANICAL SEALS SEPARATED BY AN OIL CHAMBER**

Seal Model	Shaft Diameter	Position	Materials		
			Stationary ring	Rotational ring	Elastomer
STA-22	Ø 22 mm	Motor side	Ceramic	Graphite	NBR
STA-20	Ø 20 mm	Pump side	Silicon carbide	Silicon carbide	NBR

**7 BEARINGS 6305 CM D 6 / 6204 ZZ - C3**

**8 ELECTRIC MOTOR**

**VXCm 15-20-30-F:** single-phase 230 V - 50 Hz with thermal overload protector incorporated into the winding

**VXC-F:** three-phase 400 V - 50 Hz with thermal overload protector incorporated into the winding to be connected to the control box (supplied on demand)

- Insulation: class F
- Protection: IP X8

**9 POWER CABLE**

10 metres long "H07 RN-F" cable

**10 CONTROL BOX for VXCm 15-20-30-F**

(only for single-phase versions)

Complete with capacitor and manual reset motor protector

**11 FLOAT SWITCH**

(only for single-phase versions)

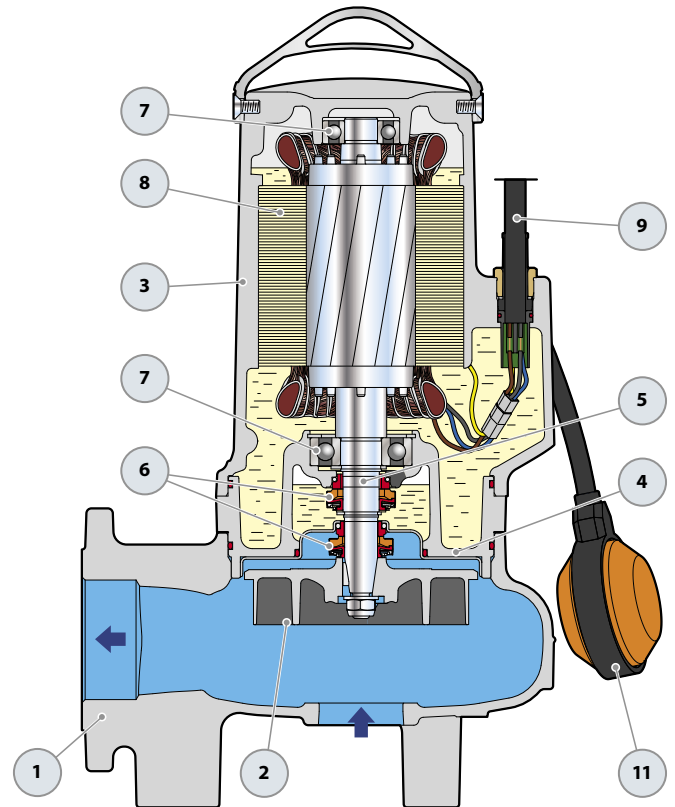

**OPTIONAL – Supporting Base**



**Standard Equipment**

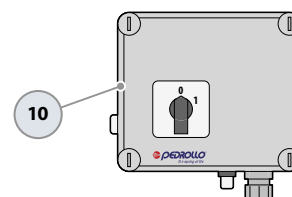

**Control Box**  
(only for single-phase versions)

## DIMENSIONS AND WEIGHT

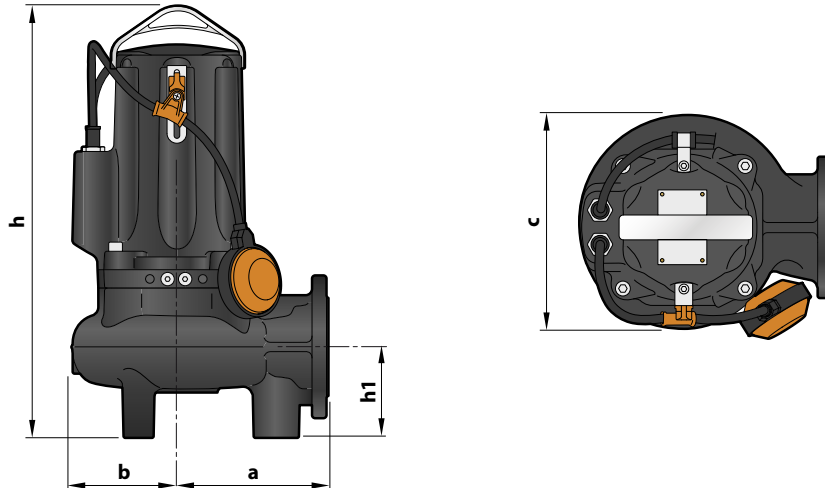

MODEL		Passage of solids	DIMENSIONS mm					kg	
Single-phase	Three-phase		a	b	c	h	h1	1~	3~
VXCm 15/50-F	VXC 15/50-F	Ø 50	170	119	242	487	102	43.5	42.0
VXCm 20/50-F	VXC 20/50-F					513   487		44.5	43.5
VXCm 30/50-F	VXC 30/50-F					513		49.5	44.5
-	VXC 40/50-F					-		-	49.5
VXCm 15/65-F	VXC 15/65-F	Ø 65	210	120	246	521	123	46.0	44.5
VXCm 20/65-F	VXC 20/65-F					547   521		47.0	46.0
VXCm 30/65-F	VXC 30/65-F					547		52.0	47.0
-	VXC 40/65-F					-		-	52.0

## ABSORPTION AND CAPACITORS

MODEL	VOLTAGE	
	230 V	240 V
Single-phase	230 V	240 V
VXCm 15/50-F	8.5 A	8.1 A
VXCm 20/50-F	9.0 A	8.6 A
VXCm 30/50-F	12.0 A	11.5 A
VXCm 15/65-F	8.5 A	8.1 A
VXCm 20/65-F	9.0 A	8.6 A
VXCm 30/65-F	12.0 A	11.5 A

MODEL	VOLTAGE		
	230-240 V	400-415 V	690-720 V
Three-phase	230-240 V	400-415 V	690-720 V
VXC 15/50-F	5.9 A	3.4 A	1.7 A
VXC 20/50-F	6.4 A	3.7 A	2.0 A
VXC 30/50-F	8.7 A	5.0 A	3.3 A
VXC 40/50-F	10.7 A	6.2 A	4.5 A
VXC 15/65-F	5.9 A	3.4 A	1.7 A
VXC 20/65-F	6.4 A	3.7 A	2.0 A
VXC 30/65-F	8.7 A	5.0 A	3.3 A
VXC 40/65-F	10.7 A	6.2 A	4.5 A

MODEL	CAPACITANCE CAPACITORS	
	(230 V o 240 V)	
Single-phase	(230 V o 240 V)	
VXCm 15/50-F	50 µF 450 VL	
VXCm 15/65-F	50 µF 450 VL	
VXCm 20/50-F	50 µF 450 VL	
VXCm 20/65-F	50 µF 450 VL	
VXCm 30/50-F	60 µF 450 VL	
VXCm 30/65-F	60 µF 450 VL	

## PORT FLANGE

MODEL	FLANGE	F	K	D	L	HOLES	
						N°	Ø (mm)
VXC /50-F	DN65 (PN10)	2½"	145	185	160	4	18
VXC /65-F	DN80 (PN10)	3"	160	200	180	8	18

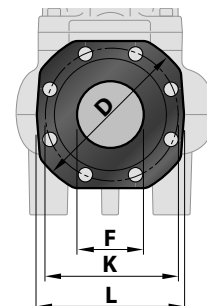

# MC-F

## Submersible pumps **DOUBLE-CHANNEL** with flanged ports

-  Sewage water
-  Domestic use
-  Civil use
-  Industrial use

- ※ An innovative project by Pedrollo's Research and Development department, has resulted in the new **MC-F**, a complete range of extremely robust and reliable electric pumps.
- ※ Thanks to the enhanced oversizing of the oil-bath electric motor, shaft and bearings, the new **MC-F** electric pumps guarantee an unprecedented service life, with high hydraulic performance, low operating costs and easy maintenance. The oil-bath motor also allows continuous operation of the electric pump, even if partially uncovered.
- ※ They are recommended in all installations for pumping waste water with suspended solid bodies up to 65 mm diameter.
- ※ The **MC-F** series is equipped with a double-channel impeller, ideal for the discharge of large volumes of waste water.



### PERFORMANCE RANGE

- Flow rate up to **1600 l/min** (96 m<sup>3</sup>/h)
- Head up to **25 m**

### APPLICATION LIMITS

- **10 m** maximum immersion depth (with a sufficiently long power cable)
- Maximum liquid temperature **+40 °C**
- Passage of solids:
  - up to **Ø 50 mm** for MC /50-F
  - up to **Ø 65 mm** for MC /65-F
- Minimum immersion depth for continuous service:
  - **320 mm** for MC /50-F
  - **360 mm** for MC /65-F

### CONSTRUCTION AND SAFETY STANDARDS

- **10 m** long power cable
- External float switch and control box for single-phase versions

### INSTALLATION AND USE

**MC-F** series pumps, made from heavy gauge robust cast iron, resistant to abrasion and long-lasting, are fitted with a **DOUBLE-CHANNEL** impeller and are capable of pumping liquids containing short fibred suspended solids. They are ideal for pumping **sewage, waste water, water mixed with mud, groundwater and surface water** in locations such as blocks of flats, public buildings, factories, multi-storey and underground car parks, washing areas, etc.

### PATENTS - TRADE MARKS - MODELS

- Patent n° IT0001428923

### OPTIONS AVAILABLE ON REQUEST

- **QES** control box for three-phase pumps
- Single-phase pumps without float switch
- Other voltages or 60 Hz frequency

### GUARANTEE

⇒ **For the following versions, to validate the guarantee, the built-in thermal overload guarantee, the built-in thermal overload control box:**

- three-phase
  - **MC 15-20-30-40/50-F**
  - **MC 30-40/65-F**

**CHARACTERISTIC CURVES AND PERFORMANCE DATA**

**50 Hz n= 2900 min<sup>-1</sup>**

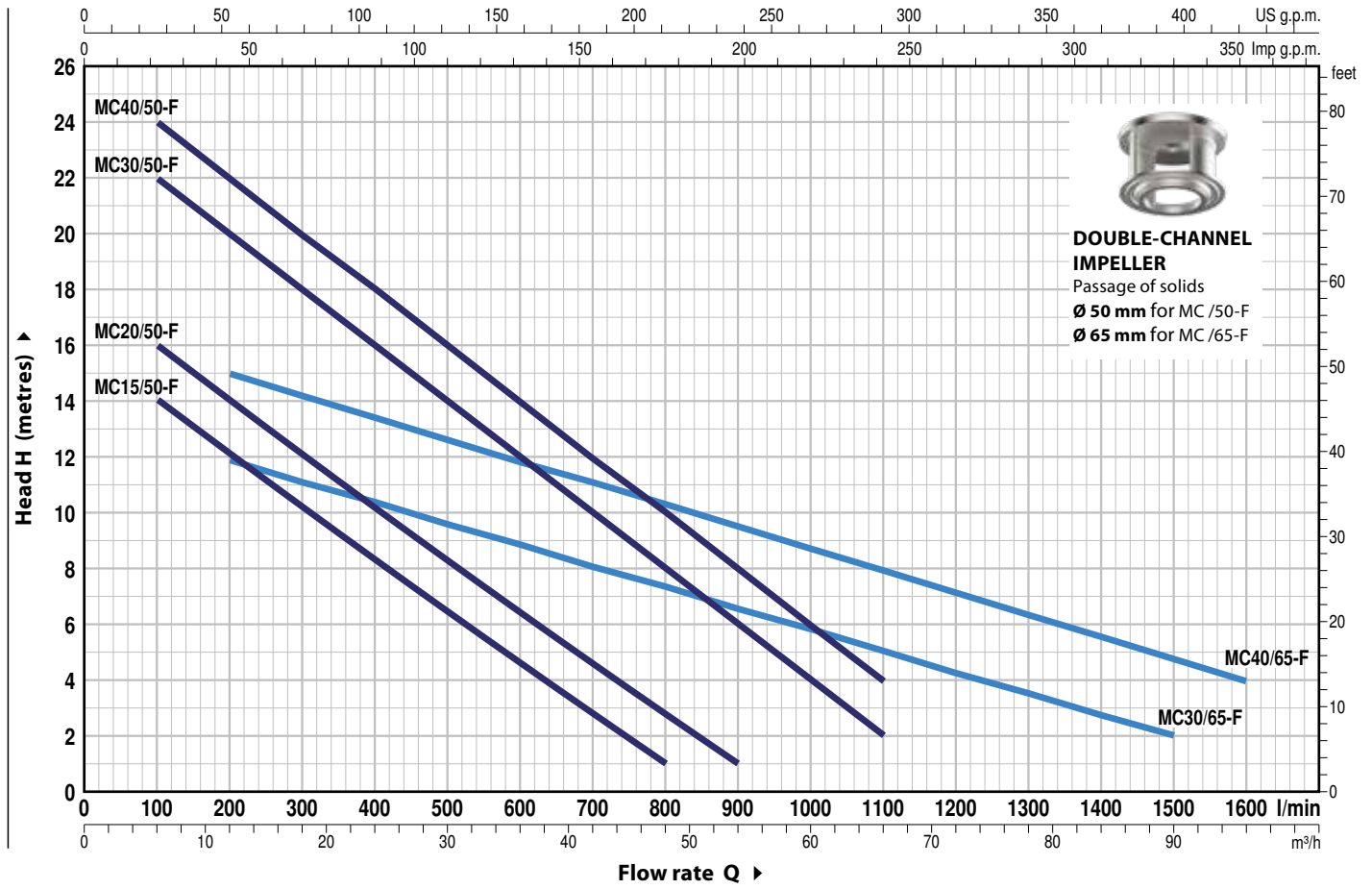

MODEL		POWER (P2)		Q	H metres															
Single-phase	Three-phase	kW	HP		m <sup>3</sup> /h	0	6	12	18	24	30	36	42	48	54	60	66	72	90	96
				l/min	0	100	200	300	400	500	600	700	800	900	1000	1100	1200	1500	1600	
MCm 15/50-F	MC 15/50-F	1.1	1.5		16	14	12.5	10.5	8.5	6.5	4.5	3	1							
MCm 20/50-F	MC 20/50-F	1.5	2		18	16	14	12.5	10.5	8.5	6.5	5	3	1						
MCm 30/50-F	MC 30/50-F	2.2	3		24	22	20	18	16	14	12	10	8	6	4	2				
-	MC 40/50-F	3	4		25	24	22	20	18	16	14	12	10	8	6	4				
MCm 30/65-F	MC 30/65-F	2.2	3		13	-	12	11	10.5	9.7	9	8	7.5	6.5	6	5	4.5	2		
-	MC 40/65-F	3	4		17	-	15	14	13.5	12.5	12	11	10.5	9.5	8.5	8	7	4.8	4	

Q = Flow rate H = Total manometric head

Tolerance of characteristic curves in compliance with EN ISO 9906 Grade 3B.

## POS. COMPONENT CONSTRUCTION CHARACTERISTICS

<b>1 PUMP BODY</b>	Cast iron with an Epoxy Electro Coating treatment, with flanged and threaded ports in compliance with ISO 228/1
<b>2 IMPELLER</b>	Precision cast stainless steel AISI 304 DOUBLE-CHANNEL type
<b>3 MOTOR CASING</b>	Cast iron with an Epoxy Electro Coating treatment
<b>4 MOTOR CASING PLATE</b>	Cast iron with an Epoxy Electro Coating treatment
<b>5 MOTOR SHAFT</b>	Stainless steel AISI 431

### 6 TWO MECHANICAL SEALS SEPARATED BY AN OIL CHAMBER

Seal Model	Shaft Diameter	Position	Materials		
			Stationary ring	Rotational ring	Elastomer
STA-22	Ø 22 mm	Motor side	Ceramic	Graphite	NBR
STA-20	Ø 20 mm	Pump side	Silicon carbide	Silicon carbide	NBR

### 7 BEARINGS 6305 CM D 6 / 6204 ZZ - C3

### 8 ELECTRIC MOTOR

**MCm 15-20-30-F:** single-phase 230 V - 50 Hz with thermal overload protector incorporated into the winding

**MC-F:** three-phase 400 V - 50 Hz. with thermal overload protector incorporated into the winding to be connected to the control box (supplied on demand)

- Insulation: class F
- Protection: IP X8

### 9 POWER CABLE

10 metres long "H07 RN-F" cable

### 10 CONTROL BOX for MCm 15-20-30

(only for single-phase versions)

Complete with capacitor and manual reset motor protector

### 11 FLOAT SWITCH

(only for single-phase versions)

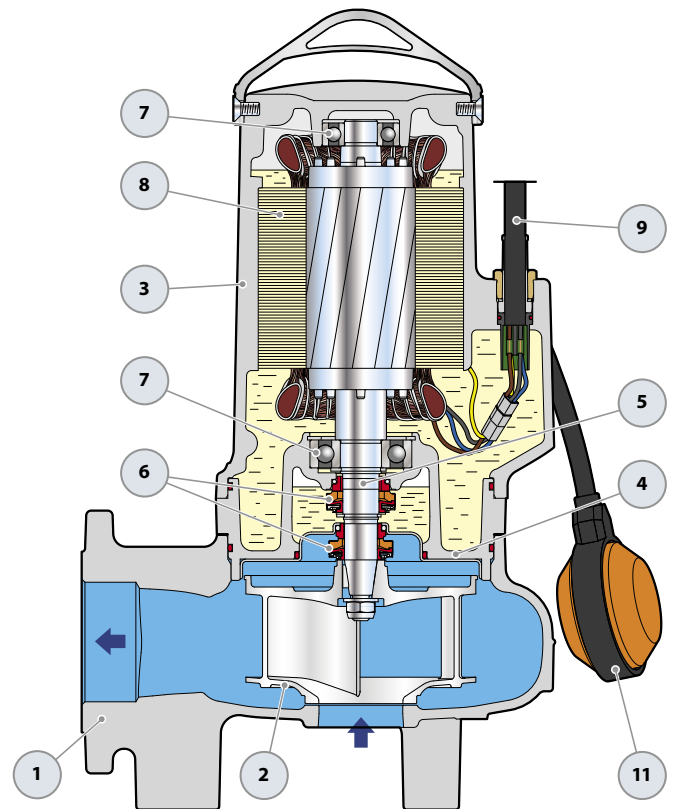

### OPTIONAL – Supporting Base



### Standard Equipment

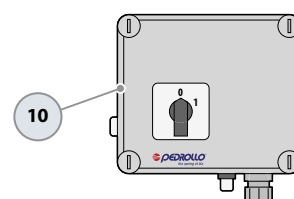

Control Box  
(only for single-phase versions)

## DIMENSIONS AND WEIGHT

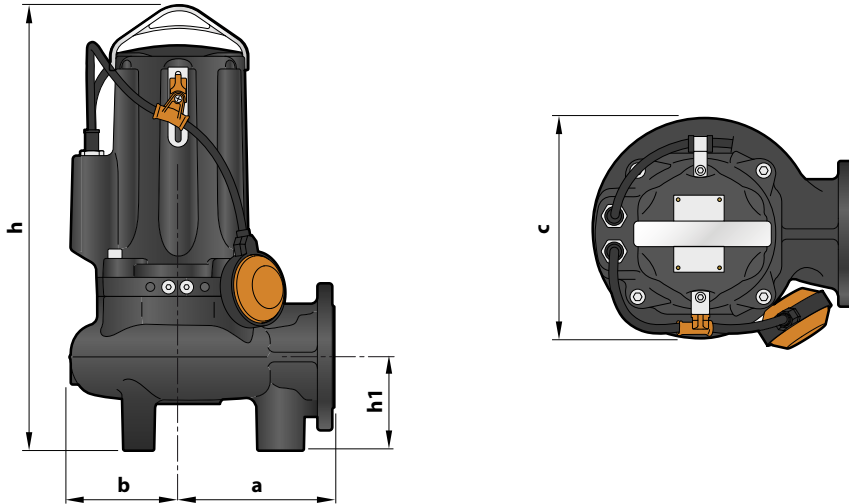

MODEL		Passage of solids	DIMENSIONS mm					kg	
Single-phase	Three-phase		a	b	c	h	h1	1~	3~
MCm 15/50-F	MC 15/50-F	Ø 50	170	119	242	487	102	43.5	42.0
MCm 20/50-F	MC 20/50-F					513   487		44.5	43.5
MCm 30/50-F	MC 30/50-F					513		-	49.5
-	MC 40/50-F					513		-	49.5
MCm 30/65-F	MC 30/65-F	Ø 65	210	120	246	547   521	123	52.0	47.0
-	MC 40/65-F					547		-	52.0

## ABSORPTION AND CAPACITORS

MODEL	VOLTAGE	
	230 V	240 V
MCm 15/50-F	10.5 A	10.1 A
MCm 20/50-F	14.0 A	13.4 A
MCm 30/50-F	18.0 A	17.3 A
MCm 30/65-F	14.0 A	13.4 A

MODEL	VOLTAGE		
	230-240 V	400-415 V	690-720 V
MC 15/50-F	7.8 A	4.5 A	2.8 A
MC 20/50-F	8.7 A	5.0 A	3.3 A
MC 30/50-F	10.4 A	6.0 A	4.3 A
MC 40/50-F	11.2 A	6.5 A	4.8 A
MC 30/65-F	9.5 A	5.5 A	3.8 A
MC 40/65-F	13.0 A	7.5 A	5.8 A

MODEL	CAPACITANCE CAPACITORS	
	(230 V or 240 V)	
MCm 15/50-F	50 µF 450 VL	
MCm 20/50-F	50 µF 450 VL	
MCm 30/50-F	60 µF 450 VL	
MCm 30/65-F	60 µF 450 VL	

## PORT FLANGE

MODEL	FLANGE	F	K mm	D mm	L mm	HOLES	
						N°	Ø (mm)
MC /50-F	DN65 (PN10)	2½"	145	185	160	4	18
MC /65-F	DN80 (PN10)	3"	160	200	180	8	18

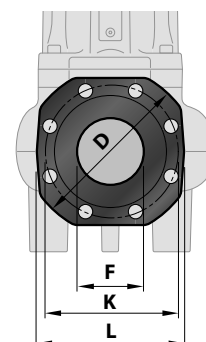

# SEWAGE LIFTING SYSTEM VXC-F – MC-F



## HORIZONTAL DELIVERY VERSION WITH ¾" GUIDE TUBES

For <b>VXC /50-F, MC /50-F</b>	Cod. ASSVXCF051	DN <b>2"</b>
--------------------------------	-----------------	--------------

Kit consisting of:

1. footing connection
2. slide guide with screws and seals
3. support for the guide tubes



## VERTICAL DELIVERY VERSION WITH ¾" GUIDE TUBES

For <b>VXC /50-F, MC /50-F</b>	Cod. ASSVXCF051V	DN <b>2½"</b>
For <b>VXC /65-F, MC /65-F</b>	Cod. ASSVXCF071V	DN <b>3"</b>

Kit consisting of:

1. footing connection completo di controflangia
2. slide guide with screws and seals
3. support for the guide tubes



## VERTICAL DELIVERY VERSION WITH 2" GUIDE TUBES

For <b>VXC /50-F, MC /50-F</b>	Cod. ASSVXCF0704V	DN <b>3"</b>
For <b>VXC /65-F, MC /65-F</b>	Cod. ASSVXCF0705V	

Kit consisting of:

1. footing connection completo di controflangia
2. slide guide with screws and seals
3. support for the guide tubes

## ACCESSORIES CAN BE ORDERED

### SLIDE GUIDE (Also to be ordered separately)

For <b>VXC /50-F, MC /50-F</b> with guide tubes Ø ¾"	Cod. ASSFL0017
For <b>VXC /65-F, MC /65-F</b> with guide tubes Ø ¾"	Cod. ASSFL0018
For <b>VXC /50-F, MC /50-F</b> with guide tubes Ø 2"	Cod. ASSFL071
For <b>VXC /65-F, MC /65-F</b> with guide tubes Ø 2"	Cod. ASSFL072

Complete with screws and seals

### INTERMEDIATE SUPPORT (To be ordered separately)

For guide tubes Ø ¾"	Cod. 859SV340INTFA
For guide tubes Ø 2"	Cod. 859SV349INTFA

**In order to ensure stability, insert the intermediate support:**

- every 2 metres with ¾" guide tubes (compulsory)
- every 3 metres with 2" guide tubes (recommended)

### GUIDE TUBES (AISI 304 stainless steel)

Guide tube Ø ¾"	Cod. 54SARTG005
Guide tube Ø 2"	Cod. 54SARTG006

Maximum length of the tube plank: 6 metres

### INTERMEDIATE SUPPORT

For guide tubes Ø ¾"



For guide tubes Ø 2"



## DIMENSIONS (Horizontal delivery version)

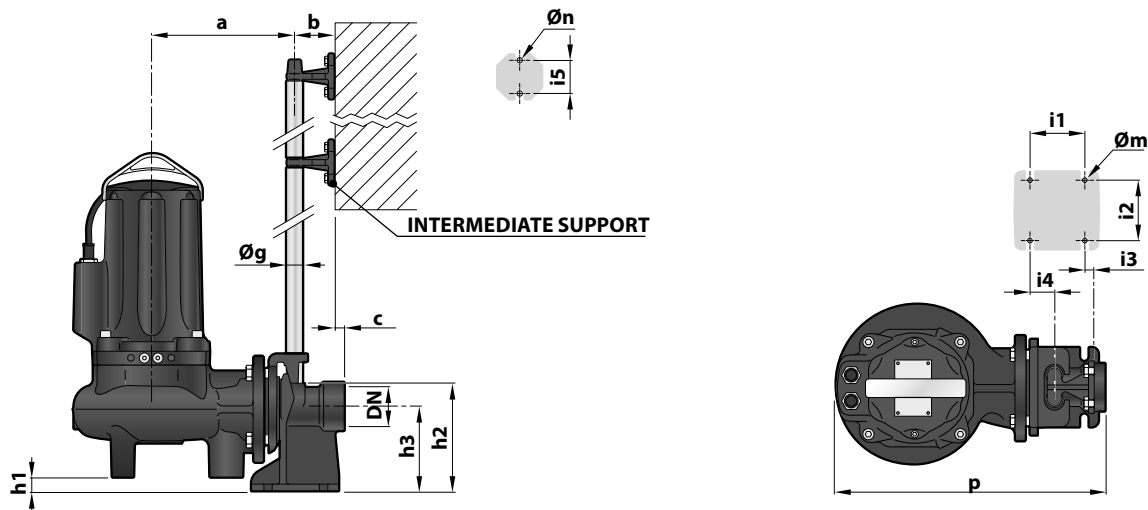

MODEL	Passage of solids mm	PORT DN	DIMENSIONS mm														
			a	b	c	p	h1	h2	h3	i1	i2	i3	i4	i5	Øg	Øm	Øn
VXC /50-F	Ø 50	2"	216	61	17	412	28	165	130	85	94	16	40	50	¾"	12	11
MC /50-F																	

## DIMENSIONS (Vertical delivery version)

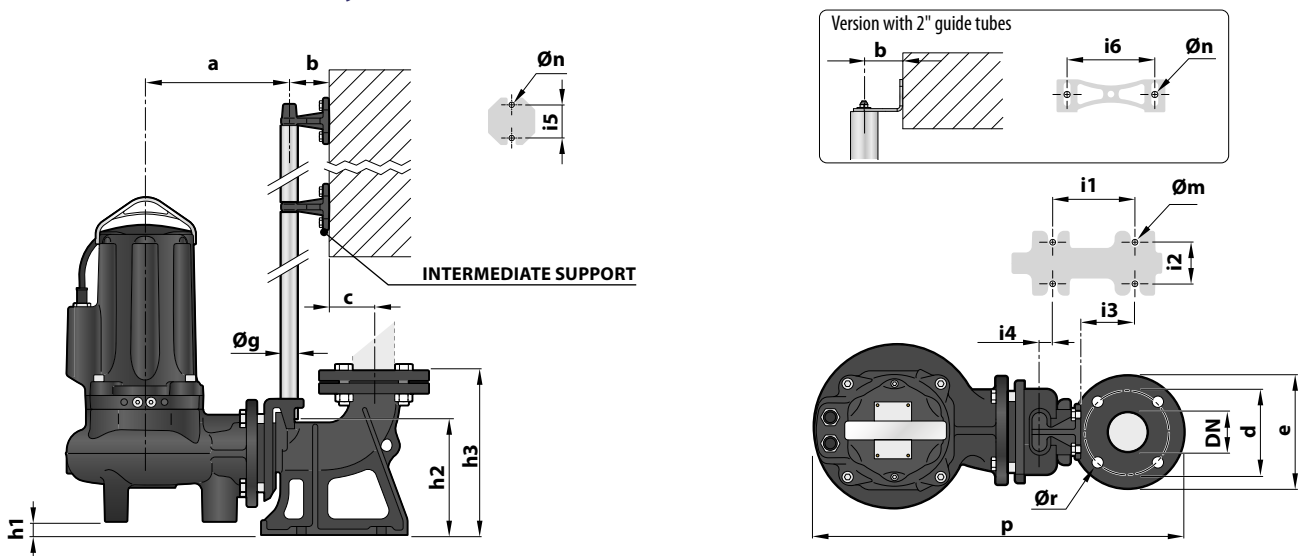

### Version with ¾" guide tubes

MODEL	Passage of solids mm	PORT DN	DIMENSIONS mm																	
			a	b	c	d	e	p	h1	h2	h3	i1	i2	i3	i4	i5	Øg	Øm	Øn	Ør
VXC /50-F	Ø 50	2½" (PN10)	213	61	52	125	165	526	25.5	164	215	120	72	62	3	50	¾"	14	11	18
MC /50-F																				
VXC /65-F	Ø 65	3" (PN6)	253	61	69	150	190	598	46	216	279	130	112	84	15	50	¾"	14	11	18
MC /65-F																				

### Version with 2" guide tubes

MODEL	Corpi solidi mm	BOCCA DN	DIMENSIONS mm																		
			a	b	c	d	e	p	h1	h2	h3	i1	i2	i3	i4	i5	i6	Øg	Øm	Øn	Ør
VXC /50-F	Ø 50	3" (PN10)	320	85	95	160	200	718	105	265	392	250	150	35	-130	-	187	2"	22	13.5	18
MC /50-F																					
VXC /65-F	Ø 65	3" (PN10)	359	85	95	160	200	760	84	256	392	250	150	35	-130	-	187	2"	22	13.5	18
MC /65-F																					

## STANDARD INSTALLATION

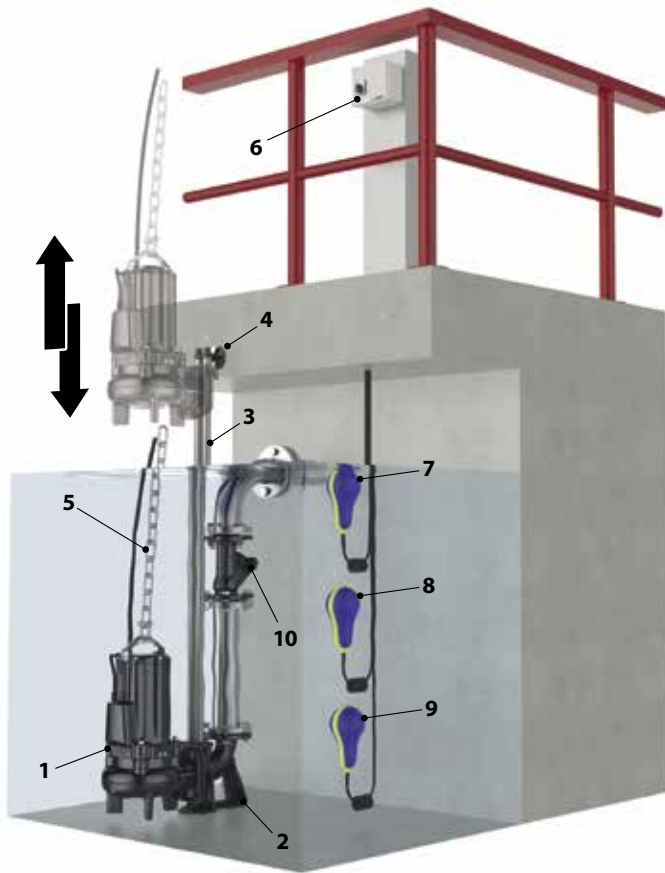

1. Pump
2. Footing connection
3. Guide tubes
4. Support for the guide tubes
5. Lifting chain
6. Control box
7. Alarm float switch
8. Starting float switch
9. Stop float switch
10. Non-return valve



### Pedrollo S.p.A.

Via Enrico Fermi, 7 - 37047 San Bonifacio (Verona) Italy  
tel. +39 045 6136311 - fax +39 045 7614663  
vendite@pedrollo.com - sales@pedrollo.com - www.pedrollo.com

**MADE IN ITALY**